



**2026 FOOD SERVICE LINES  
BID #6204**

**PORT HURON NORTHERN HIGH SCHOOL**

**ISSUE DATE: APRIL 30TH, 2026**

**DUE DATE: MAY 15TH, 2026**

**BID DOCUMENTS**

## ADVERTISEMENT FOR BIDS

**PROJECT:** Food Service Lines at Port Huron Northern High School, Port Huron, Michigan.

**OWNER:** PORT HURON AREA SCHOOL DISTRICT  
2720 Riverside Drive  
Port Huron, Michigan 48060  
Telephone: (810) 984-3101

### PROJECT DESCRIPTION

Port Huron Area School District will accept sealed proposals for the Food Service Lines at Port Huron Northern High School, 1799 Krafft Road, Port Huron, MI 48060.

For a pre-bid meeting, please schedule with Mary Kurkowski, (810) 984-2671.

### PROPOSALS

The Port Huron Area School District will receive sealed proposals until: 2:00 p.m., local time, May 15th, 2026 at the Administrative Offices of the Port Huron Area School District, 2720 Riverside Drive, Port Huron, Michigan 48060, Attention: Kate Peternel, Chief Financial Officer. Label outside of envelopes "PHN Food Service Lines". Faxed proposals will not be accepted. The District will not consider or accept a bid received after this date and time. All proposals will be publicly opened and read aloud. All interested parties are invited to attend.

Evaluation of the proposal and awards by Port Huron Schools will be available at a later date.

### BIDDING DOCUMENTS

Bidders may obtain copies of the Bidding Documents, including drawings, specifications, proposal form, and disclosure forms, from the district's website - [www.phasd.us/about\\_us/business\\_services](http://www.phasd.us/about_us/business_services) - or by contacting the purchasing department at 810.984.3101, ext. 4031.

### BID PROPOSAL GUARANTEE

Each proposal must be accompanied by an acceptable bid security in the form of a certified check, cashier's check or standard form bid bond, made payable to the Port Huron Area School District in an amount of not less than five percent (5%) of the base bid submitted. Failure of any accepted Bidder to enter into contract for the work will cause forfeit of his bid security. After contracts for the work have been signed, all bid securities will be returned.

### DISCLOSURES

As required by State Law (P.A. 232 of 2004) all proposals/bids must be accompanied by a sworn and notarized statement disclosing any familial relationship that exists between the Owner or any employee of the bidder and any member of the Port Huron Area School District Board or the Superintendent of the School District. Additionally, as required by State Law (P.A. 517 of 2012), the bidder must certify that it is not an Iran linked business as defined by P.A. 517 and that it will comply with the district's criminal background check requirements. The Board will not accept a bid that does not include these sworn and notarized statements.

### RIGHTS RESERVED BY THE OWNER:

The Owner reserves the right to waive any irregularity or informality in bids, to reject any and/or all bids, in whole or in part, or to award any Contract to other than the low bidder, should it be deemed in the Owner's best interest to do so.

Signed: Kate LaFore, Chief Financial Officer, Port Huron Area School District

END OF ADVERTISEMENT FOR BIDS

# PROJECT SPECIFICATIONS – PORT HURON NORTHERN HIGH SCHOOL

## BASIS OF DESIGN FOR PROJECT TO INCLUDE THE FOLLOWING:

Brands specified are the basis of Design and alternates to said brands have not been approved for this project.

## PROJECT REFERENCE DRAWING:

### **OVERALL LINEUP – REFERENCE ONLY**

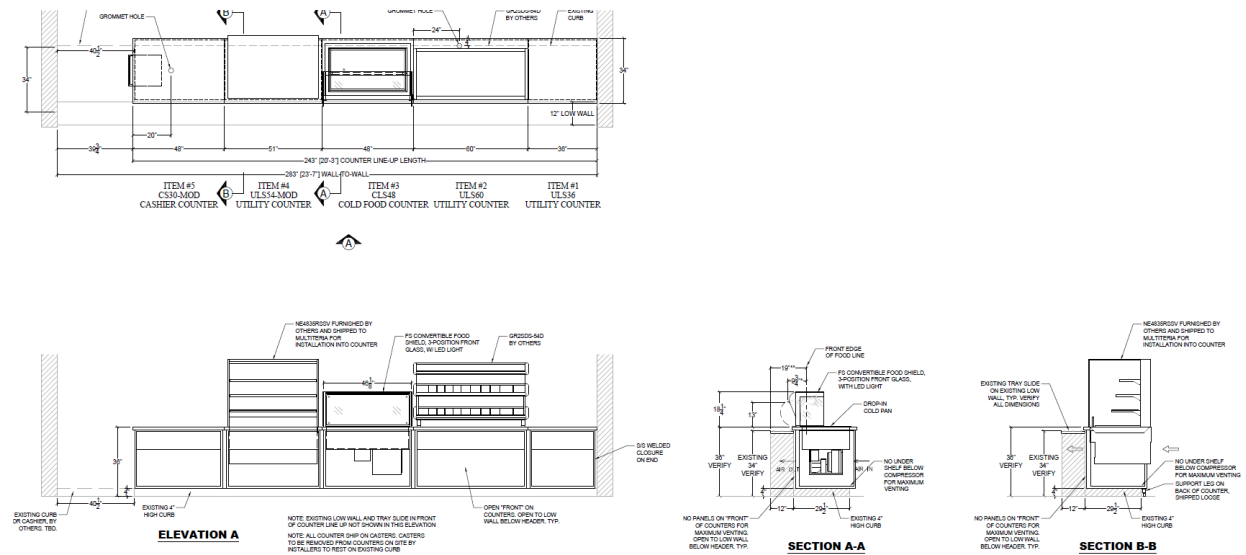

## A. SCOPE OF WORK FOR PROJECT TO INCLUDE THE FOLLOWING:

1. Remove, and dispose of any existing equipment as needed.
2. Make the room ready to accept all final furnishings.
3. Provide dumpsters on site during delivery for disposal of packaging materials.
4. Owner/School to take care of any ceiling tile repairs after completion of project
5. Dealer to perform the following work:
  1. Confirm all utilities prior to release of equipment from factory
  2. Sign off on all required shop drawings confirming direction, voltage, sizes, and any other necessary items to release.
  3. Provide signed off on shop drawing to owner for records
6. Coordinate with different trades on timing of equipment delivery and with the owner.
7. Provide owner operating manuals in digital form and any operational training videos by manufacturer.
8. Coordinate factory-rep training with the owner's staff at completion of the project.
9. Any work not included within specs that is required/needed by the dealer must bring this to the attention of the owner at time of RFP.
10. All project labor must be paid prevailing wage rates, the cost of which shall be included in the bid.

11. Must provide 5% bid bond and complete required disclosures (Familial Disclosure, Iran Sanctions Act and Criminal Background Checks).

## **EQUIPMENT SPECIFICATIONS-PORT HURON NORTHERN**

### **ITEM 1-CUSTOM**

**MFR: MULTITERIA (1 Requested)**

**MODEL: ULS36**

Essence Utility Counter  
ULS36, 36" L x 34" W x 38" H w/  
Stainless Steel Top  
S/S Panels with Standard Essence Corners  
Front Panel  
Standard Caster  
Tightlink  
To ship on casters. Casters to be removed from counters on site by installers to rest on existing curb  
No front panel or end panel  
S/S welded closure on end

### **ITEM 2-CUSTOM**

**MFR: MULTITERIA (1 Requested)**

**MODEL: HLS72**

Multiteria Essence Hot Food Counter  
HLS72, 72 L X 34 W X 34 H W/ stainless steel top  
S/S Panels with Standard Essence Corners  
Front Panel  
Standard Caster  
Tightlink  
GRSBF-66-I drop-in aluminum heated shelf w/ flush top 72" FS Food Shield with Polished Finish, LED Lights, and Food Warmer  
To ship on casters. Casters to be removed from counters on site by installers to rest on existing curb  
No front panel

### **ITEM 3-CUSTOM**

**MFR: MULTITERIA (1 Requested)**

**MODEL: CLS48**

Essence Cold Food Counter  
CLS48, 48 L x 34 W x 38 H w/  
Stainless Steel Top  
S/S Panels with Standard Essence Corners  
Front Panel  
Standard Caster  
Tightlink  
Operator Side Doors  
CWBP-3 drop-in-pan cold pan  
48" FS Food Shield with Polished Finish and LED Lights  
To ship on casters. Casters to be removed from counters on site by installers to rest on existing curb  
No front panel  
S/S closure on "front" with louvers

**ITEM 4-CUSTOM**

**MFR: MULTITERIA (1 Requested)**

**MODEL: ULS54**

Multiteria Essence Utility Counter

ULS54, 51 L x 34 W x 38 H w/

Stainless Steel Top

S/S Panels with Standard Essence Corners

Front Panel

Standard Caster

Tightlink

To ship on casters. Casters to be removed from counters on site by installers to rest on existing curb

No front panel

No doors at the compressor. Back of counter open for maximum venting

Electrical recp in counter base w/ 8' cord set

Install Structural Concepts NE4835RSSV into counter

Install on site by others

**ITEM 4.1-REFRIGERATED DISPLAY CASE, SLIDE IN COUNTER (1 Requested)**

**MFR: STRUCTURAL CONCEPTS**

**MODEL: NE4835RSSV**

**Reveal Self-Service Refrigerated Slide In Counter Case, 47-<sup>3</sup>/<sub>4</sub>" (W) x 33" D x 35-<sup>3</sup>/<sub>8</sub> H (Overall) Breeze-E (Type II) self-contained refrigeration, (3) removable & adjustable clear glass shelving, LED top & shelf lights, slide in base, glass ends, upper rear solid back panel, coated coil, condensate pan, cETLus, ETL-Sanitation**

1-NOTE: If GFCI is required, a GFCI breaker MUST be used in lieu of a GFCI receptacle

1-NESHIPNOTE must ship prepaid/add SCC will ship via air ride truck using a carrier that will not transfer the freight

1-1 yr. parts & labor warranty, 5 yr. compressor warranty, standard

1-Model HEIGHTNOTE2 Minimum of 19-1/4" space required beneath counter surface

Due to DOE regulations the maximum counter height on this model is 30"

1-Refrigeration: Breeze-E (Type II) self-contained refrigeration rear access, (R290) standard

1-Electrical Connection: 10 ft Straight blade power cord (self-contained), NEMA 6-20P, standard

1-Interior Color: Powder coated SCC Standard Silversan Black (FDA compliant)

1-Frame Exterior: Powder coated SCC Standard Silversan Black (FDA compliant), standard

1-Left End Glass: Glass end, standard

1-Right End Glass: Glass end, standard

1-Rear Doors: Clear Glass rear sliding doors

1-Lights: LED 3500K with frost lens, standard

1-Rear Vented Panel: None, standard

1-Night curtain, retractable, non-locking

**ITEM 5-CUSTOM (1 Requested)**

**MFR: MULTITERIA**

**MODEL: CS30**

Multiteria Essence Cashier Stand

CS30, 60 L x 34 W x 34 H w/

Stainless Steel Top

S/S Panels with Standard Essence Corners

Front Panel

Standard Caster

To ship on casters. Casters to be removed from counters on site by installers to rest on existing curb

No front panel

Grommet hole in counter top  
Locking cash drawer

**ITEM 6- WORK TABLE, STAINLESS STEEL TOP**

**MFR: EAGLE GROUP T3096SEB**

Deluxe Series Work Table, 96" W x 30" D, 16/300 series stainless steel top, rolled edge on front & back, adjustable 430 stainless steel undershelf with marine edge, Uni-Lok gusset system, (6) stainless steel legs & adjustable bullet feet, NSF

**ITEM # 7 :INSTALL SCOPE BY INSTALLATION CONTRACTOR**

*Scope of work:*

*Receive, inspect, deliver, and install new serving lines on existing curb. (1) 36" utility counter, (1) 72" hot food counter, (1) 48" cold food counter, (1) 51" utility counter, (1) 60" cashier counter. \*Includes removal and disposal of similar existing equipment. \*Does NOT include any field welds of modifications to equipment. \*Does NOT include stair transport*

**ITEM 8: FREIGHT**

**END OF EQUIPMENT SPECIFICATIONS**

Merchandise: \_\_\_\_\_  
Freight: \_\_\_\_\_  
Total: \_\_\_\_\_

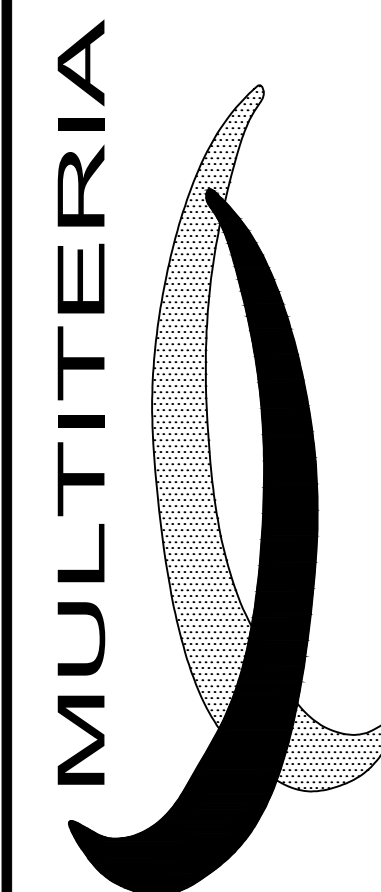

MULTITERIA RESERVES THE RIGHT TO THIS DRAWING AND THE DATA SHOWN THEREON. THIS DRAWING AND/OR DATA BE CLASSIFIED AS CONFIDENTIAL AND ARE NOT TO BE USED OR REPRODUCED FOR ANY PURPOSE WITHOUT WRITTEN CONSENT OF MULTITERIA.

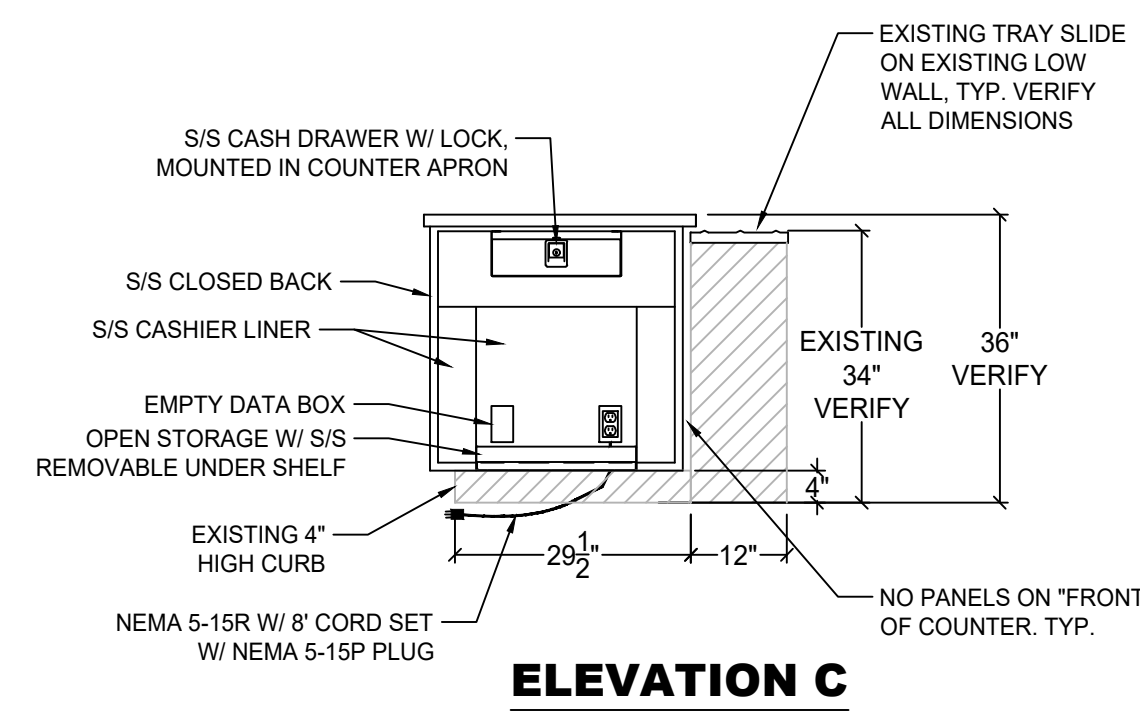
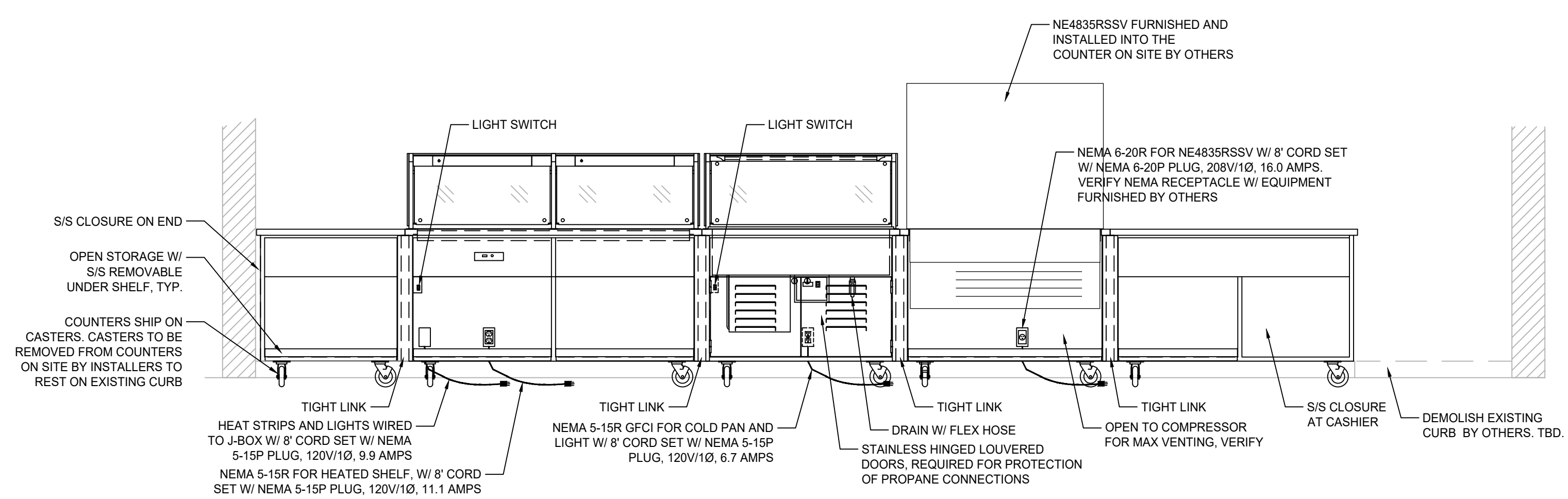
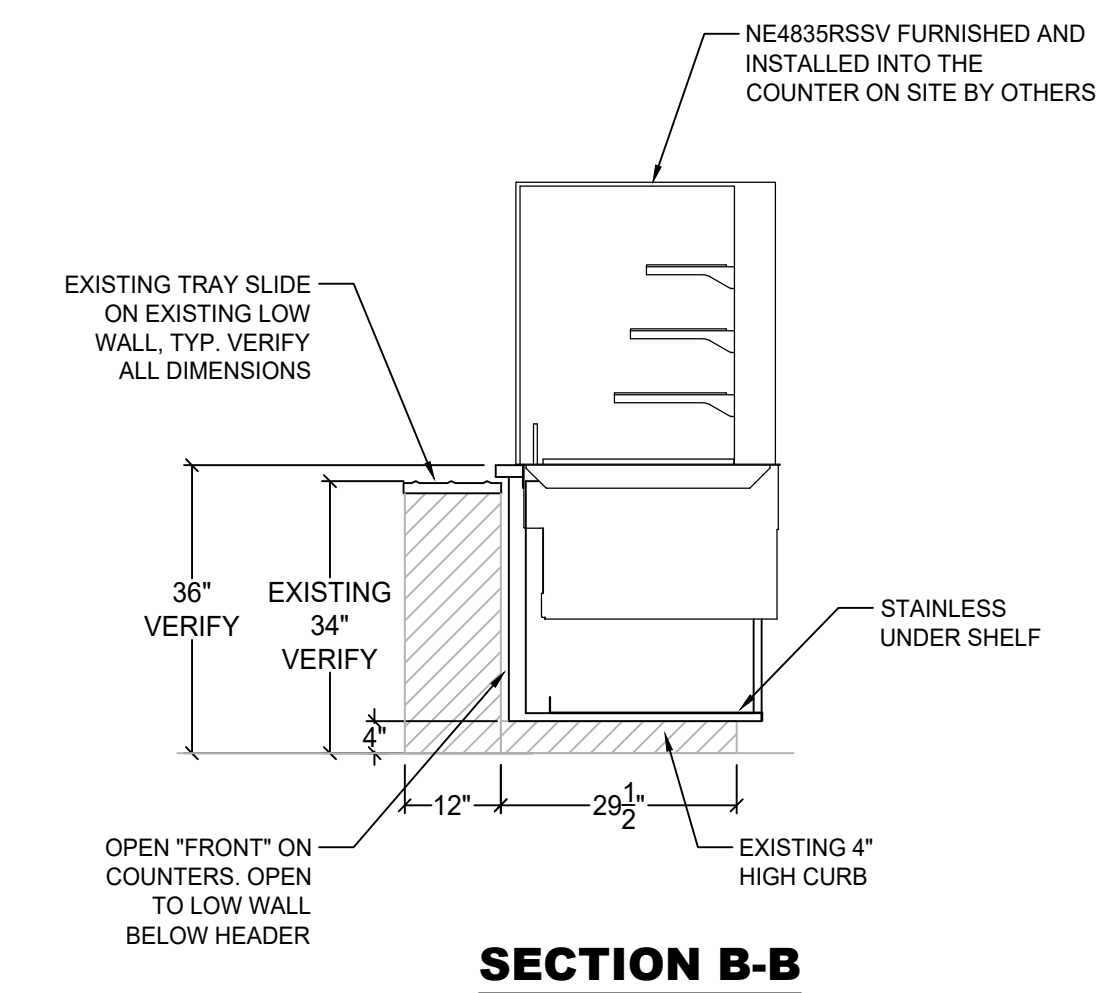
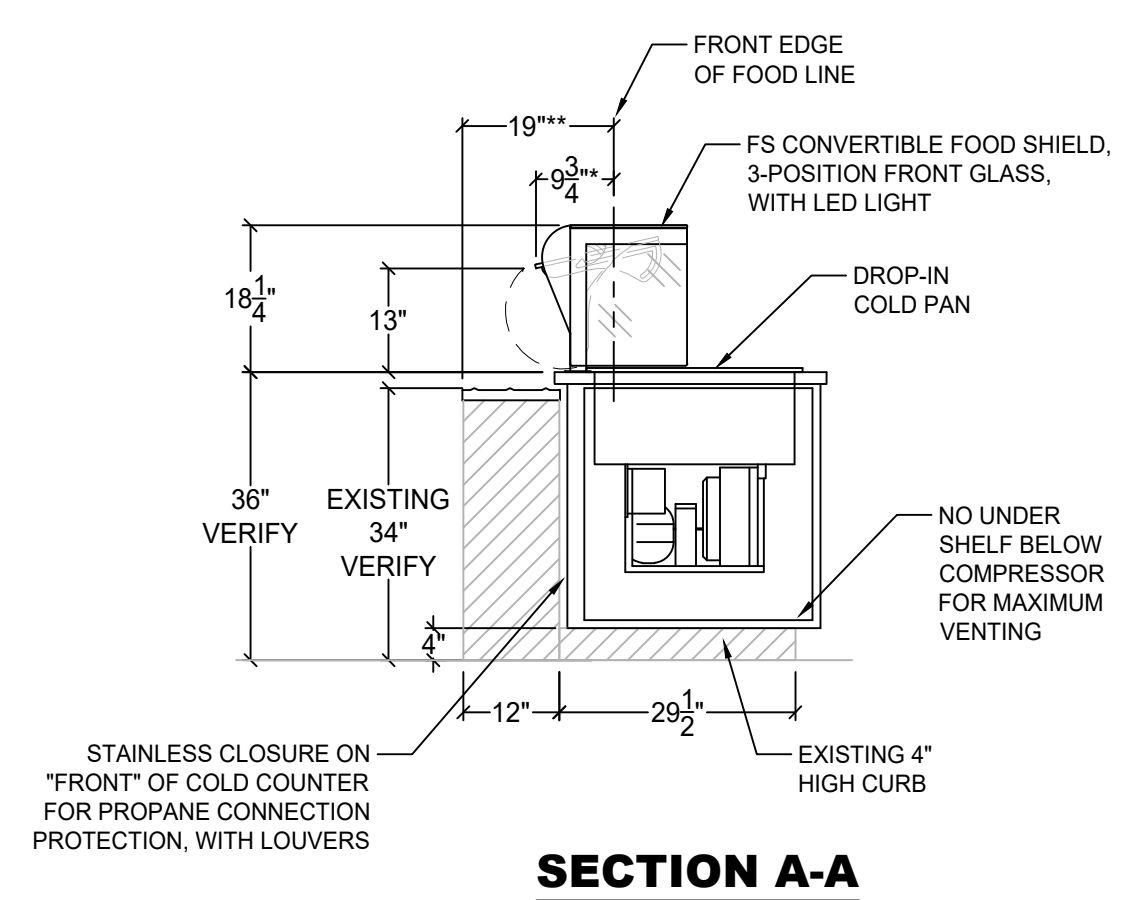
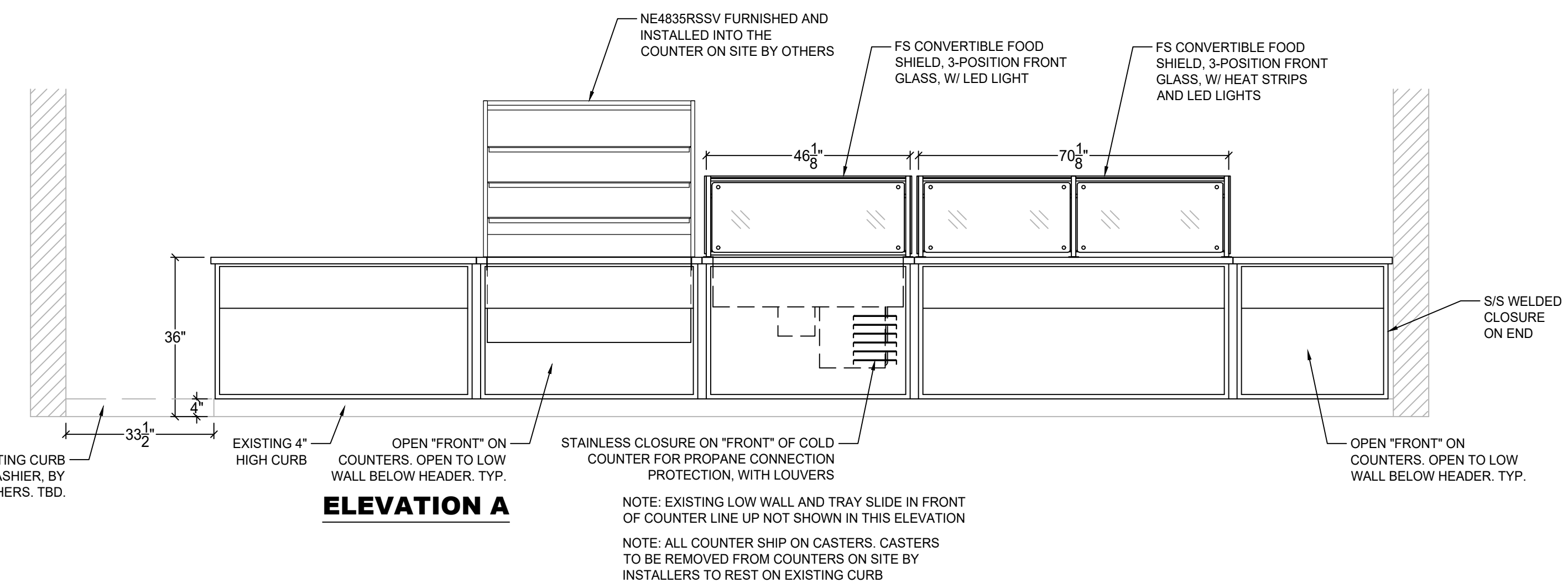
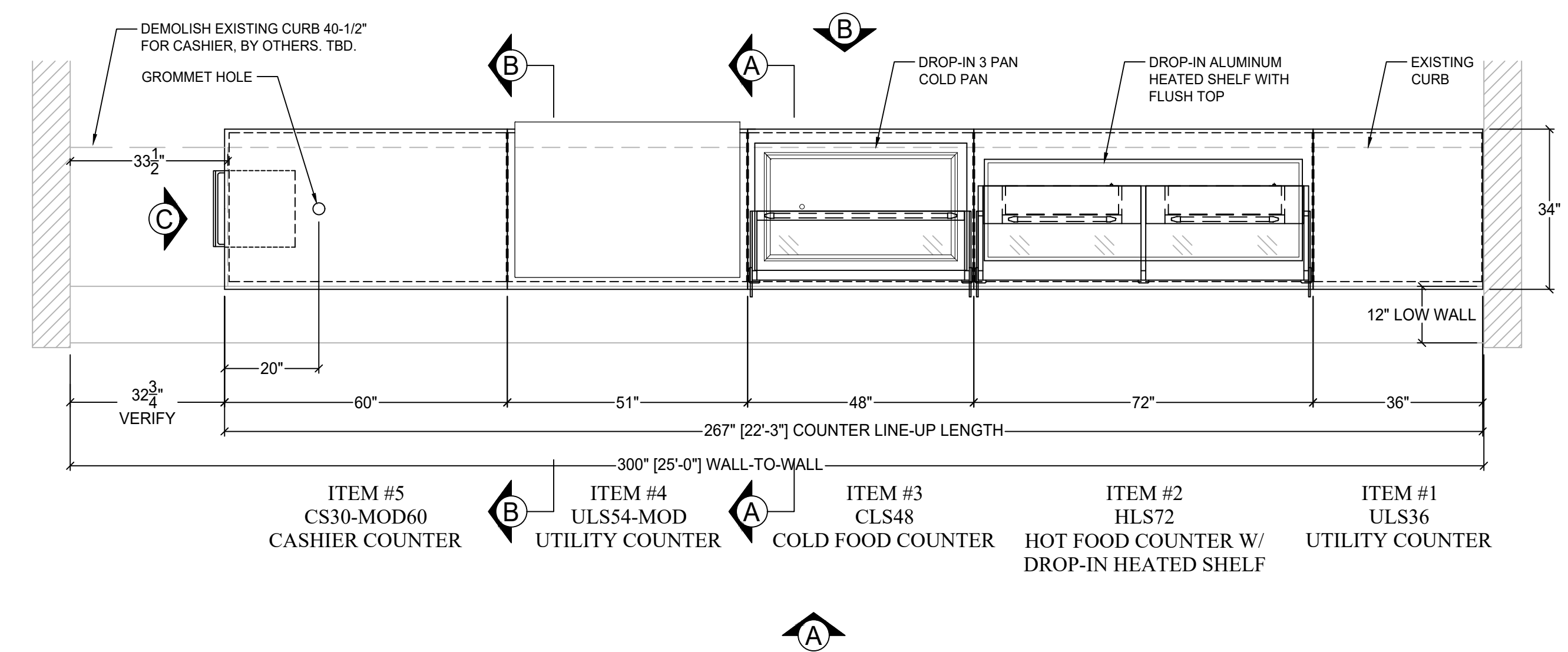

ELEVATION B

ELEVATION C

MATERIAL/COLOR SELECTIONS TO BE SPECIFIED / VERIFIED:

- COUNTER TOP: 14 GA. STAINLESS STEEL
- FOOD SHIELD: STAINLESS STEEL BRUSHED FINISH
- NO PANELS

MANUFACTURING NOTES:

- 1" SQUARE STAINLESS STEEL, WELDED TUBULAR FRAMEWORK.
- ALL COUNTER SHIP ON CASTERS. CASTERS TO BE REMOVED FROM COUNTERS ON SITE BY INSTALLERS TO REST ON EXISTING CURB
- DRAIN LINES TO HAVE PLASTIC TUBE DRAIN LINE EXTENSION WITH SHUT-OFF VALVE.



FSEC TO VERIFY ALL DELIVERY ACCESSES (LOADING DOCK, DOORS, HALLWAYS, ELEVATORS, ETC.) WILL ACCOMMODATE COUNTER SIZES AS SHOWN

ITEM #	QTY	MFR	MODEL #	DESCRIPTION	PO NOTES
2	1	HATCO	GRSBF-66-1	DROP-IN ALUMINUM HEATED SHELF W/ FLUSH TOP, 120V	MULTITERIA
2	2	HATCO	GRAH-24	HEAT STRIP, 120V	MULTITERIA
3	1	HATCO	CWBP-3	DROP-IN 3 PAN COLD PAN	MULTITERIA

- PRELIMINARY DRAWING NOT FOR CONSTRUCTION
- SUBMITTAL DRAWING FOR APPROVAL
- RESUBMITTAL DRAWING FOR APPROVAL
- AS-BUILT DRAWING

KEC SIGNATURE \_\_\_\_\_ DATE \_\_\_\_\_  
 APPROVED AS DRAWN  
 APPROVED AS NOTED  
 REVISE AND RESUBMIT

**Bid #6204 Proposal Form**  
**2026 Port Huron Area School District**  
**Food Service Line**  
**Port Huron Northern High School**

NAME OF BIDDER: \_\_\_\_\_

ADDRESS: \_\_\_\_\_

PHONE : (\_\_\_\_) \_\_\_\_\_ FAX: (\_\_\_\_) \_\_\_\_\_

E-MAIL: \_\_\_\_\_

TO: Kate LaFore, Chief Financial Officer  
Port Huron Area School District  
2720 Riverside Drive  
Port Huron, MI 48060

Bids are due: May 15th, 2:00pm

The undersigned having become fully conversant with all the existing dimensions and conditions, and having examined the Plans and Specifications for this project, hereby submits the following bid for your consideration:

**Base bid for Port Huron Northern High School: \$ \_\_\_\_\_**

**The Port Huron School District reserves the right to reject any or all bids and to waive any irregularities.**

Signature of Contractor: \_\_\_\_\_

Printed Name and Title: \_\_\_\_\_

Date: \_\_\_\_\_



**AFFIDAVIT OF COMPLIANCE – CRIMINAL BACKGROUND CHECKS**

The undersigned, the owner or authorized officer of \_\_\_\_\_ (the "Contractor"), pursuant to the criminal background compliance certification requirements of the Port Huron Area School District (the "School District"), hereby certifies, represents and warrants that the Contractor has performed and/or will perform sufficient criminal background checks, including, at a minimum, an Internet Criminal History Tool ("ICHAT") check, for all of the owners, employees, agents, representatives, contractors and/or other personnel who will be on any School District premises to carry out the services contemplated by the Contract documents. The Contractor further hereby certifies that no owner, employee, agent, representatives, contractor and/or other personnel of the Contractor will be on any School District premises if they are a registered criminal sex offender under the Sex Offenders Registration Act, Public Act 295 of 1994, or have been convicted of "Listed Offences" as defined under Section 722 of the Sex Offenders Registration Act, MCL 28.722

The Contractor further acknowledges that if it is found to have submitted a false certification or otherwise fails to comply with the requirements of this certification, the School District may immediately terminate the Contract.

Signature \_\_\_\_\_ Title: \_\_\_\_\_

Name of firm: \_\_\_\_\_

STATE OF MICHIGAN

COUNTY OF \_\_\_\_\_

On this \_\_\_\_\_ day of \_\_\_\_\_, 20\_\_\_\_, before me a Notary Public in and for said county, personally appeared \_\_\_\_\_, agent of the firm \_\_\_\_\_, and who acknowledged the same to his free act and deed as such agent.

\_\_\_\_\_  
Notary Public

**SWORN AND NOTARIZED AFFIDAVIT OF COMPLIANCE - IRAN ECONOMIC SANCTIONS ACT**  
**Michigan Public Act No. 517 of 2012**

All bidders must submit the following certification statement in compliance with Public Act No. 517 of 2012 (the "Iran economic sanctions act") and attach this form to the bid. **The Port Huron Area School District shall not accept a bid that does not include this sworn and notarized certification statement.** This form must be completed in its entirety.

The undersigned, the owner or authorized officer of \_\_\_\_\_ (the "Contractor"), pursuant to the compliance certification requirement provided in the Port Huron Area School District (the "School District") Request for Proposal, hereby certifies, represents and warrants that the Contractor (including its officers, directors and employees) is not an "Iran linked business" within the meaning of the Iran Economic Sanctions Act, Michigan Public Act No. 517 of 2012 (the "Act"), and that in the event the Contractor is awarded a contract as a result of the aforementioned Request for Proposal, the Contractor will not become an "Iran linked business" at any time during the course of performing the work or any services under the contract.

The Contractor further acknowledges that any person who is found to have submitted a false certification is responsible for a civil penalty of not more than \$250,000.00 or 2 times the amount of the contract or proposed contract for which the false certification is made, whichever is greater, the cost of the School District's investigation, and reasonable attorney fees, in addition to the fine. Moreover, any person who submitted a false certification shall be ineligible to bid on a request for proposal for three (3) years from the date it is determined that the person has submitted the false certification.

Signature \_\_\_\_\_ Title: \_\_\_\_\_

Name of firm: \_\_\_\_\_

STATE OF MICHIGAN

COUNTY OF \_\_\_\_\_

On this \_\_\_\_\_ day of \_\_\_\_\_, before me a Notary Public in and for said county,  
personally appeared \_\_\_\_\_, agent of the firm \_\_\_\_\_,  
and who acknowledged the same to his free act and deed as such agent.

\_\_\_\_\_  
Notary Public



**SWORN AND NOTARIZED FAMILIAL DISCLOSURE STATEMENT**

All bidders must submit the following familial disclosure statement in compliance with Section 1267 of the Revised School Code (MCL 380.1267) and attach this form to the bid. **The Port Huron Area School District shall not accept a bid that does not include this sworn and notarized disclosure statement.** The Familial Disclosure Statement form must be completed in its entirety.

**By this sworn and notarized statement, I am disclosing the familial relationship(s) that exists between the owner(s) or any employee of the firm and any member of the Port Huron Area School District Board or the Superintendent of Port Huron Area School District as follows:** (Please provide owner/employee name, position, name of relative and the nature of the familial relationship or state NONE).

**The following are the familial relationship(s):**

Owner/Employee Name	Position	Name of Relative (Board Member/Superintendent)	Nature of Relationship
_____	_____	_____	_____
_____	_____	_____	_____
_____	_____	_____	_____
_____	_____	_____	_____
_____	_____	_____	_____

Attach additional pages if necessary to disclose familial relationships

**There is no familial relationship that exists** between the owner or key employee of the Vendor submitting a proposal and any member of the Port Huron Area School District Board or the Port Huron Area School District Superintendent.

Signature \_\_\_\_\_ Title: \_\_\_\_\_

Name of firm: \_\_\_\_\_

STATE OF MICHIGAN

COUNTY OF \_\_\_\_\_

On this \_\_\_\_\_ day of \_\_\_\_\_, 20\_\_\_\_, before me a Notary Public in and for said county, personally appeared \_\_\_\_\_, agent of the firm \_\_\_\_\_, and who acknowledged the same to his free act and deed as such agent.

\_\_\_\_\_  
Notary Public

TERMS & CONDITIONS FOR  
PROVIDING CONTRACTED SERVICES  
THE PORT HURON AREA SCHOOL DISTRICT

1. Quotations to be submitted and signed with contractor's name and by a responsible officer or employee. Obligations assumed by such signature are binding upon the contractor.  
  
Quotations must be received by date specified on the face of this request. Late quotations cannot be accepted.
2. Prices for materials are to be F.O.B. job site delivered and/or installed and are to be firm for 60 days from due date. No charges for packing, drayage, or for any other purpose will be allowed over the price quoted hereon.
3. The Board of Education reserves the right to reject any or all quotations, to evaluate suggestions or exceptions and to accept the quotation best suited to the interest of the District.
4. As a condition of accepting this contract, the Subcontractor agrees not to discriminate against any individual with respect to hire, discharge, compensation, terms, conditions or privileges of employment, or segregation of facilities because of such individual's race, color, religion, sex, age, handicap or national origin.
5. Contractor will comply with Federal, State and Municipal laws, rules and regulations in the performance of the work and in the employment of persons, and shall obtain all necessary licenses and permits and pay all fees, taxes and other charges required thereby, and furnish, upon Owner's request, evidence of compliance with any law and the payment of any fee, tax or charge. Contractor will indemnify and hold harmless Owner against any and all claims, charges, liens, garnishments and levies arising out of Contractor's failure to comply as required by this paragraph.
6. Contractor shall keep the premises, Owner's funds, and the work to which this contract relates free and clear of all claims and mechanics liens, and will promptly pay for all labor (including social security contributions and fringe benefits), material and services used in connection with this contract. Contractor shall furnish Owner such certificate of payment, waivers of claims (including claims against any payment bond), waivers of mechanics liens, releases and sworn statements in form satisfactory to the Owner when submitting request for payment for work completed. The contractor further shall indemnify and hold harmless the Owner on account of the contractor and sub-contractors accessed against the Owner under authority of said Act and Public Laws of said state.
7. To the fullest extent permitted by law, the contractor shall indemnify and hold harmless the Owner and its agents, employees, officers and successors from and against any and all liabilities, claims, causes of action or lawsuits seeking damages on account of personal injury or death to any person, including employees of the contractor, or property damage, including claims for loss of use which arise out of performance of this contract by the contractor. The contractor's indemnity obligation shall include:
  - a. Indemnity even if the damages sought were caused in part by the negligence or fault of Owner or any of its employees, agents or officers,
  - b. Indemnity for all damages and judgment interest, all costs and fees, including attorney's fees, relating to or arising out of any claim, cause of action or lawsuit requiring indemnity by the contractor.
  - c. All expenses incurred in securing indemnity from the contractor if the contractor wrongfully refuses to fulfill any of the indemnity obligations assumed under this contract.

The contractor's obligation to indemnify shall not include any obligation to indemnify which is prohibited by Michigan MCLA 691.991 or other comparable state law. Owner, at its option, may select counsel to defend any claim, cause of action or lawsuit brought against it without impairing any obligation to indemnify imposed upon the contractor hereunder.

Contractor will keep in force during contract, policies of insurance covering Workers' Compensation and Employer's Liability, Automobile Liability and Commercial General Liability, with minimum limits as provided below or as modified by the Contract Documents, if any, or satisfactory to Owner with an insurance company in good standing licensed to operate in the State of Michigan. Contractor will advise its insurer of its obligations and will obtain a contractual coverage endorsement to its property damage and personal injury insurance sufficient to discharge its obligations therein set forth. Contractor will furnish, before any work is started, certificates from said insurance companies showing the limits and expiration dates.

STANDARD INSURANCE REQUIREMENTS are as follows:

A. Insurance Coverage

As a condition of performing work for us as a contractor, you must provide us with satisfactory evidence of your insurance coverage as follows:

1. Workers' compensation and employer's liability insurance covering your statutory obligations in the State.
2. Automobile liability insurance with the limit of \$500,000 per accident covering your owned, non-owned and hired automobiles.
3. Commercial general liability insurance written on an OCCURRENCE policy that includes coverage for your operations, personal injury, XCU (explosion, collapse and underground), independent contractors, contractual, and products-completed operations with limits of liability as follows:
  - a. If your policy is written on the 1986 ISO Simplified Form:

\$ 500,000 Occurrence	\$1,000,000 General Aggregate
\$1,000,000 Products-Completed Operations Aggregate	

If your policy's general aggregate is per job, then a \$500,000 limit of liability is acceptable for the general aggregate and the products-completed operations aggregate.

- b. If your policy is written on a form other than the 1986 ISO Simplified Form:
  - \$500,000 Occurrence (Bodily injury and property damage combined)
  - \$500,000 Aggregate (Applicable to products-completed operations only)
- c. Products-completed operations liability must be maintained for not less than one year after acceptance of completion of your work.

**B. OTHER REQUIREMENTS:**

- 1. Evidence of your insurance coverage, required herein, is to be provided to us on ACORD Certificate Form 26 or 25-S and must indicate:
    - a. That your Commercial Liability insurance policy includes coverage for items specified in A.3 above.
    - b. A Best's rating for each of your insurance carriers at B+ VII or better.
    - c. That the issuing insurance company will provide thirty (30) days written notice of cancellation to the certificate holder and the words "endeavor to" and "but failure to mail such notice shall impose no obligation or liability of any kind upon the company, its agents or representatives" do not apply or have been removed.
    - d. That Owner is additional insured on the General Liability policy certificate.
    - e. Any deviations in coverage provided by the Standard 1986 ISO General Liability policy form, and
    - f. Any deductibles over \$2,500 applicable to any coverage.
  - 2. General liability and auto liability limits may be attained by individual policies or by a combination of underlying policies with umbrella and/or excess liability policies.
  - 3. The contractor waives subrogation rights against the Owner for property damage to property covered by valid and collectible property insurance, and will include this same requirement in contracts with its subcontractors and suppliers. If the policies of insurance referred to in this paragraph require an endorsement to provide for continued coverage where there is a waiver of subrogation, the owners of such policies will cause them to be so endorsed.
  - 4. Contractor will provide contractor's equipment floater coverage and agrees it and its insurance carriers will waive subrogation against Owner for claims paid by such insurance.
- C. You may prevent unnecessary follow up resulting from incomplete insurance certificates by sending or faxing a copy of these insurance requirements to your agent when you request an insurance certificate.
- 8. The latest Michigan State Laws and Regulations regarding sales and use tax shall apply and the cost of same shall be included in the proposals.
  - 9. The contractor shall notify the Owner of the names and addresses of all sub-contractors to be employed on the project. Contractor agrees that Owner has the right to approve or disapprove subcontractors performing work for the successful contractor on Owner's property.
  - 10. Contractor is fully responsible for safety, and agrees to cooperate with Owner on any overall project safety program, to submit its own trade related safety program and rules, to take all reasonable precautions for the safety of employees on the project, to actively assist in the prevention of accident injury to persons or property in, about or adjacent to the premises where work is being performed, and to comply with all Federal, State and Local safety laws and ordinances applicable to the work.

Contractor shall comply with all requirements of any State or Federal Right-To-Know Law, especially: (1) contractor shall provide Owner with a copy of all Material Safety Data Sheets (MSDS) for each hazardous chemical, and have a copy of same available for employees; (2) shall provide required training of its employees; (3) submit a copy of its written Hazard Communication Program to Owner, and (4) properly label all containers of hazardous chemicals that are brought on the job site or used in the performance of this contract. Failure to comply with the foregoing requirements will be considered a material breach of contract.

The contractor is responsible for reviewing the Material Safety Data Sheets (MSDS) at the project building location to insure that any employees assigned to perform work at said site are aware of the location(s) of hazardous material(s) and the appropriate MSDS.

For all projects involving possible personnel exposure to asbestos-containing materials (ACM), all persons employed by the contractor to work on said project(s) must have received appropriate training in accordance with OSHA and MDPH regulations. The contractor will insure that said employees will have reviewed the Owner's asbestos management plan to insure that ACM are

not disturbed during work activities. If ACM must be disturbed during activities, the contractor must notify Operations Division at 984-6570 prior to the start of work.

All labor, materials and equipment consumed or supplied under this contract shall conform to provisions of the Williams-Steiger Occupations Safety and Health Act of 1970, as amended, and the General Safety Rules and Regulations for the Construction Industry, as amended. It shall be the responsibility of Contractor to furnish its employees a place of employment free from recognized hazards that are causing or likely to cause death or serious physical harm. Contractor shall be liable for damages as the result of the failure of its employees to follow the provisions as set forth above. Contractor will indemnify and hold harmless Owner against any and all fees or fines which may result from Contractor's failure to comply with the requirements set forth above.

11. Job site is to be inspected to insure an understanding of our needs. Contact the Operations Division at 984-6565 for access. Contractor shall be responsible for the layout and correctness of its work. If Contractor shall (a) fail to correct, replace and/or re-execute faulty or defective work and/or materials furnished under this contract, (b) fail to complete or diligently proceed with this contract within the time period herein provided, (c) fail to correct or repair any damage to work caused by it or by its failure to protect its work, or (d) be unable to proceed with the work because of any action by one or more employees of Contractor or by a person or labor organization purporting or attempting to represent any employee of Contractor, then Owner may consider a material breach has occurred, and, upon three (3) days notice to Contractor, shall have the right, but not the duty, to correct, replace and/or re-execute such faulty, defective or damaged work or to take over its contract with all materials, tools and appliances of Contractor on the premises, and to complete the contract, charging the cost, including, but not limited to, any and all legal fees and costs, to monitor the work thereof to Contractor. Under such circumstances, Owner shall also have the right to withhold any and all payments to Contractor until all such cost charges have been paid in full to Owner. Further, if Contractor shall fail to complete its work on time, resulting in loss or damage to Owner, whether or not damages are stated liquidated damages in the contract/documents, Owner shall be entitled to recover any damages caused by Contractor's breach. The remedies of Owner provided by law, by this paragraph and by the contract documents shall be cumulative.
12. Contractor will, at all times, keep the job clean and clear of all debris and rubbish resulting from its operations, and, upon completion of its work, will promptly remove all tools, equipment and excess material and any rubbish caused by its work and personnel. Contractor will protect all its materials and work from hazards and be full responsible for their condition until accepted by the Owner, and shall also be responsible for any damage caused by it to the work or property of others, including, but not limited to, the property of the Owner. Contractor will reimburse Owner for any expenses incurred to keep the job clean and clear of all debris and rubbish resulting from Contractor's failure to comply with this paragraph.
13. Contractor shall not use or permit any of their employees to use any equipment, hoists, staging, scaffolds, or any other material belonging to the Owner without prior written agreement.
14. Contractor shall not permit any of their employees to smoke while on the job site.
15. The contract includes the general conditions, specifications and drawings, all addenda hereto (hereinafter collectively referred to as the contract documents), or related documents covering the work to be performed under the contract between Owner and Contractor, as if herein set forth. It does not include Contractor's quotation. To the extent applicable and not inconsistent with the documents described in the preceding sentence, and/or with the provisions hereof, arbitration shall not be considered part of this contract. NOTWITHSTANDING anything to the contrary, Owner and Contractor expressly agree that Owner has the contractual right to withhold from payment to Contractor a percentage as retention until final acceptance, and that Contractor's rights to retention does not vest until time of final payment from Owner and is therefore not considered as due and owing until that time, and that the right to retention is expressly conditioned upon final payment being made by the Owner.
16. This Agreement constitutes the entire understanding of the parties and supersedes any prior proposal or agreement, and shall not be modified, amended or revoked except in writing executed by Owner. Should any portion of this contract be held invalid or unenforceable, the remainder of the contract shall be valid and enforceable to the fullest extent permitted by law. The failure of Owner to enforce at any time any of the provisions of this Agreement, or to require at any time performance by the Contractor of any of the provisions hereof, shall in no way be construed to be a waiver, nor in any way to affect the validity of this Agreement or any part thereof or the right of Owner to thereafter enforce each and every provisions. Reference in this agreement to Contractor's quotation or bid does not imply acceptance of any terms and conditions in such quotation or bid. Any terms and conditions of such quotation or bid which are in addition to or inconsistent with the terms and conditions contained in this Agreement shall not be part of this Agreement.
17. An acknowledgment of acceptance which contains terms in addition to or inconsistent with the terms and conditions of this Agreement, or a rejection of any term of this Order, shall be deemed to be a counter-offer to Owner and shall not be binding upon Owner unless acceptance thereof is made in writing to the Contractor. However, performance by Contractor in the absence of written acceptance of such counter-offer by Owner shall be deemed to be performance in accordance with the terms of this Order.

18. Contractor will submit to Owner applications for payment in duplicate on or before the 25th of the month, or at such other times stipulated by Owner. Owner's obligation to pay the Contractor is expressly preconditioned on account of the Contractor's work, less any retainage held by the Owner. Release of payment for stored material shall be at the discretion of Owner. Documentation of such stored material may be required of Contractor, including, but not limited to, (a) Bill of Sale, (b) Insurance Certificate providing coverage of stored material. Owner shall have the right to inspect materials during business hours. However, no payment shall be taken as an admission by Owner of the amount of work done, its classification, quality, sufficiency or the sum due Contractor or as an acceptance or release of Contractor from responsibility under the terms of this contract. As to work performed, all funds owed to a subcontractor or material man shall be segregated and as such held in trust for the subcontractor, sub-subcontractor or material man, as the case may
- be. It is agreed between Owner and Contractor that any amounts which may be charged as backcharge to the Contractor will no longer be considered as monies owed to the Contractor.

When the work is judged ready for final cleaning and inspection, the Contractor will arrange to clean up his work and promptly put all work in condition for final inspection. The final inspection shall be made by an authorized representative of the Owner and the Contractor for the phase of work to be inspected.

In addition to specified guarantees required by the specifications for the work performed under this contract, the Contractor shall guarantee all the work against defects in materials and workmanship for a period of one (1) year. He shall repair any damage to other work caused by such defects at his own expense and without cost to the Owner.

Final payment to the Contractor shall not be made until all items on the final inspection list have been satisfactorily completed, all written guarantees, as required in the specifications, have been executed and verified certificates that all bids and claims have been satisfied are turned over to the Owner.